

Our associates will ensure the tool works properly before you leave the store. If you experience issues with the tool while completing your project, simply bring it back to the Tool Rental Center to get a replacement. If you purchase Damage Protection at the time of your rental, you are not responsible for repair costs for tools that break due to normal use.

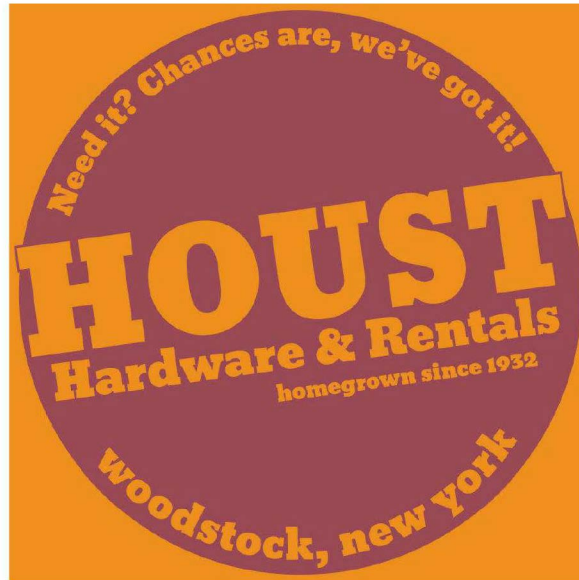

HONDA

Power

Equipment

Owner's Manual

GENERATOR

EU3000is

Click here to save this manual to your computer.

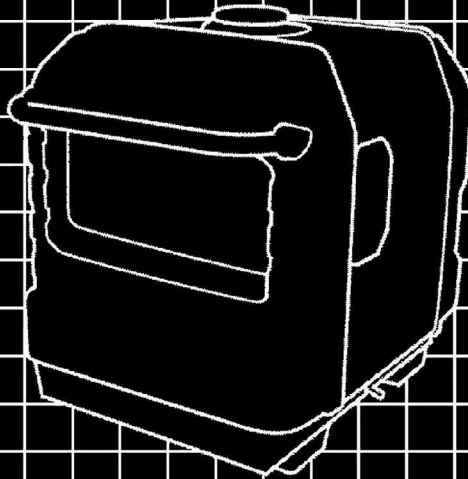



WARNING:



The engine exhaust from this product contains chemicals known to the State of California to cause cancer, birth defects or other reproductive harm.

⚠ WARNING

Exhaust contains poisonous carbon monoxide gas that can build up to dangerous levels in closed areas. Breathing carbon monoxide can cause unconsciousness or death.

Never run the generator in a closed, or even partly closed area where people may be present.

Keep this owner's manual handy so that you can refer to it at any time. This owner's manual is considered a permanent part of the generator and should remain with the generator if resold.

The information and specifications included in this publication were in effect at the time of approval for printing. Honda Motor Co., Ltd. reserves the right, however, to discontinue or change specifications or design at any time without notice and without incurring any obligation whatever.

INTRODUCTION

Congratulations on your selection of a Honda generator. We are certain you will be pleased with your purchase of one of the finest generators on the market.

We want to help you get the best results from your new generator and to operate it safely. This manual contains all the information on how to do that; please read it carefully.

As you read this manual, you will find information preceded by a **NOTICE** symbol. That information is intended to help you avoid damage to your generator, other property, or the environment.

We suggest you read the *Distributor's Limited Warranty* (see page 79) to fully understand its coverage and your responsibilities of ownership.

When your generator needs scheduled maintenance, keep in mind that your Honda servicing dealer is specially trained in servicing Honda generators and is supported by the parts and service divisions of American Honda. Your Honda servicing dealer is dedicated to your satisfaction and will be pleased to answer your questions and concerns.

The illustrations herein are mainly based on: NON-CALIFORNIA TYPE
• The illustration may vary according to the type.

Best Wishes,
Honda Motor Co., Ltd.

A FEW WORDS ABOUT SAFETY

Your safety and the safety of others are very important. And using this generator safely is an important responsibility.

To help you make informed decisions about safety, we have provided operating procedures and other information on labels and in this manual. This information alerts you to potential hazards that could hurt you or others.

Of course, it is not practical or possible to warn you about all the hazards associated with operating or maintaining a generator. You must use your own good judgement.

You will find important safety information in a variety of forms, including:

- **Safety Labels** — on the generator.
- **Safety Messages** — preceded by a safety alert symbol  and one of three signal words, DANGER, WARNING, or CAUTION.

These signal words mean:

▲ DANGER

You **WILL** be **KILLED** or **SERIOUSLY HURT** if you don't follow instructions.

▲ WARNING

You **CAN** be **KILLED** or **SERIOUSLY HURT** if you don't follow instructions.

▲ CAUTION

You **CAN** be **HURT** if you don't follow instructions.

- **Safety Headings** — such as *IMPORTANT SAFETY INFORMATION*.
- **Safety Section** — such as *GENERATOR SAFETY*.
- **Instructions** — how to use this generator correctly and safely.

This entire book is filled with important safety information — please read it carefully.

CONTENTS

GENERATOR SAFETY	6
IMPORTANT SAFETY INFORMATION	6
Operator Responsibility.....	6
Carbon Monoxide Hazards.....	6
Electric Shock Hazards	7
Fire and Burn Hazards	7
Refuel With Care	8
SAFETY LABEL LOCATIONS	9
CONTROLS & FEATURES	11
COMPONENT & CONTROL LOCATIONS	11
CONTROLS	13
Engine Switch.....	13
Starter Grip	13
Fuel Valve Lever	14
Choke Knob	14
Eco-Throttle Switch	15
Parallel Operation Outlets	15
AC Circuit Protector	16
DC Receptacle	16
DC Circuit Protector	16
FEATURES	17
Output Indicator	17
Overload Indicator	17
Oil Alert Indicator	18
Ground Terminal.....	18
BEFORE OPERATION	19
ARE YOU READY TO GET STARTED?	19
Knowledge.....	19
IS YOUR GENERATOR READY TO GO?	19
Check the Engine.....	20

CONTENTS

OPERATION	21
SAFE OPERATING PRECAUTIONS	21
STARTING THE ENGINE	22
STOPPING THE ENGINE	26
AC OPERATION.....	27
AC Applications.....	28
AC PARALLEL OPERATION	29
AC Parallel Operation Applications	31
DC OPERATION.....	33
ECO-THROTTLE SYSTEM	36
STANDBY POWER.....	37
Connections to a Building's Electrical System.....	37
System Ground	37
Special Requirements.....	38

GENERATOR SAFETY

IMPORTANT SAFETY INFORMATION

Honda generators are designed for use with electrical equipment that has suitable power requirements. Other uses can result in injury to the operator or damage to the generator and other property.

Most injuries or property damage can be prevented if you follow all instructions in this manual and on the generator. The most common hazards are discussed below, along with the best way to protect yourself and others.

Operator Responsibility

- Know how to stop the generator quickly in case of emergency.
- Understand the use of all generator controls, output receptacles, and connections.
- Be sure that anyone who operates the generator receives proper instruction. Do not let children operate the generator without parental supervision.

Carbon Monoxide Hazards

- Exhaust contains poisonous carbon monoxide, a colorless, odorless gas. Breathing carbon monoxide can cause loss of consciousness and may lead to death.
- If you run the generator in an area that is confined, or even partly enclosed area, the air you breathe could contain a dangerous amount of exhaust gas.
- Never run your generator inside a garage, house, or near open windows or doors.

Electric Shock Hazards

- The generator produces enough electric power to cause a serious shock or electrocution if misused.
- Using a generator or electrical appliance in wet conditions, such as rain or snow, or near a pool or sprinkler system, or when your hands are wet, could result in electrocution. Keep the generator dry.
- If the generator is stored outdoors, unprotected from the weather, check all of the electrical components on the control panel before each use. Moisture or ice can cause a malfunction or short circuit in electrical components that could result in electrocution.
- Do not connect to a building's electrical system unless an isolation switch has been installed by a qualified electrician.
- Use only a Honda approved parallel operation cable kit (optional equipment) when connecting two EU3000is generators for parallel operation.
- Never connect different generator models.

Fire and Burn Hazards

- The exhaust system gets hot enough to ignite some materials.
 - Keep the generator at least 3 feet (1 meter) away from buildings and other equipment during operation.
 - Do not enclose the generator in any structure.
 - Keep flammable materials away from the generator.
- The muffler becomes very hot during operation and remains hot for a while after stopping the engine. Be careful not to touch the muffler while it is hot. Let the engine cool before storing the generator indoors.

GENERATOR SAFETY

Refuel With Care

Gasoline is extremely flammable, and gasoline vapor can explode. Allow the engine to cool if the generator has been in operation. Refuel only outdoors in a well-ventilated area with the engine off. Do not overfill the fuel tank. Never smoke near gasoline, and keep other flames and sparks away. Always store gasoline in an approved container. Make sure that any spilled fuel has been wiped up before starting the engine.

GENERATOR SAFETY

SAFETY LABEL LOCATIONS

These labels warn you of potential hazards that can cause serious injury. Read them carefully.

If a label comes off or becomes hard to read, contact your Honda generator dealer for a replacement.



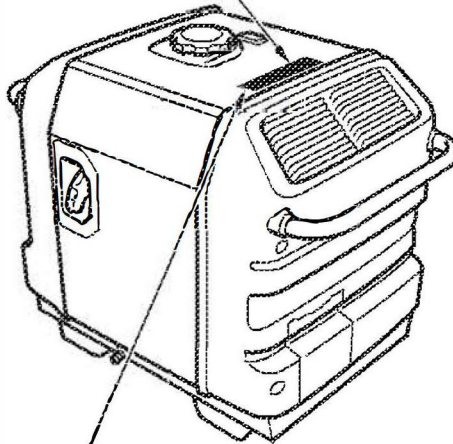
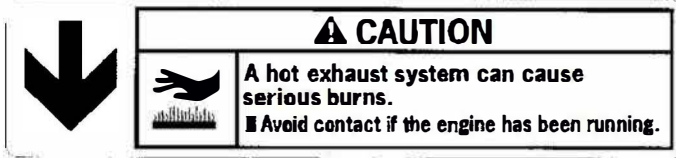

Non-California type

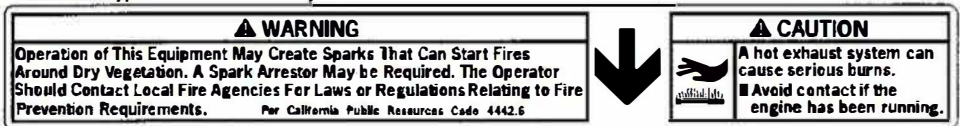

California type



GENERATOR SAFETY

⚠ DANGER		⚠ WARNING		⚠ WARNING	
<p>Using a generator indoors CAN KILL YOU IN MINUTES. Generator exhaust contains carbon monoxide. This is a poison you cannot see or smell.</p>		<p>Gasoline is highly flammable and explosive. You could be burned or seriously injured if the gasoline is ignited.</p> <ul style="list-style-type: none"> ⚠ Before refueling, stop the engine and keep heat, sparks, and flame away. ⚠ Handle fuel only outdoors. ⚠ Do not fill the fuel tank above the upper limit line. ⚠ Wipe up spills immediately. 		<p>Improper connections to a building can allow electrical current to backfeed into utility lines, creating an electrocution hazard.</p> <ul style="list-style-type: none"> ⚠ Connections to a building must isolate generator power from utility power and comply with all applicable laws and electrical codes. 	
 <p>NEVER use inside a home or garage, EVEN IF doors and windows are open.</p>	 <p>Only use OUTSIDE and far away from windows, doors, and vents.</p>	 <p>Exhaust contains poisonous carbon monoxide gas that can build up to dangerous levels in closed areas. Breathing carbon monoxide can cause unconsciousness or death.</p> <ul style="list-style-type: none"> ⚠ Never run the generator in a closed, or even partly closed area where people may be present. 	 <p>The generator is a potential source of electrical shock if not kept dry.</p> <ul style="list-style-type: none"> ⚠ Do not expose the generator to moisture, rain or snow. ⚠ Do not operate the generator with wet hands. 	 <p>Read owner's manual carefully before operation.</p>	

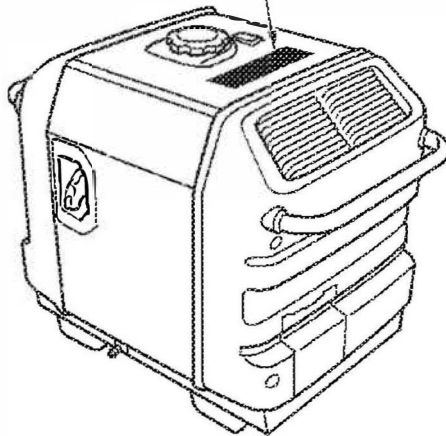

CONTROLS & FEATURES

COMPONENT & CONTROL LOCATIONS

Use the illustrations on these pages to locate and identify the most frequently used controls.

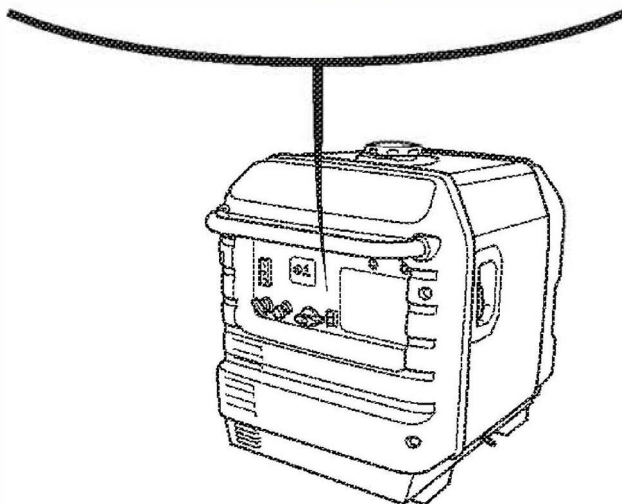
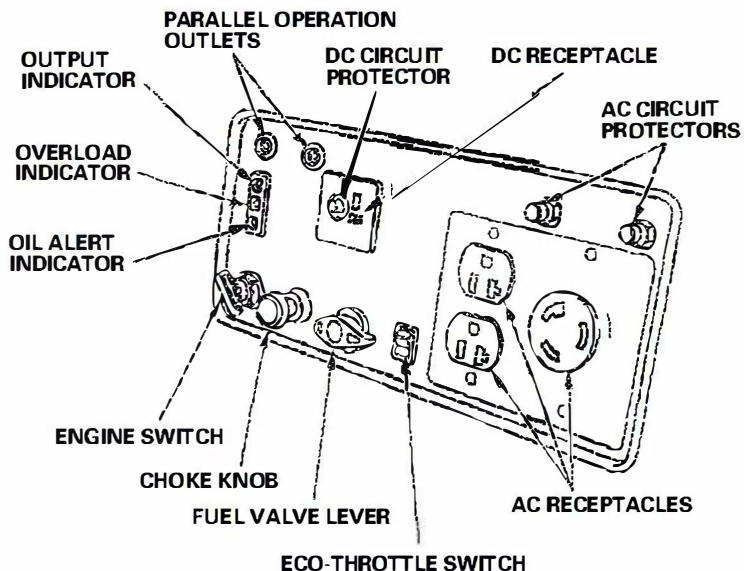

CONTROLS & FEATURES

<NON-CALIFORNIA TYPE>

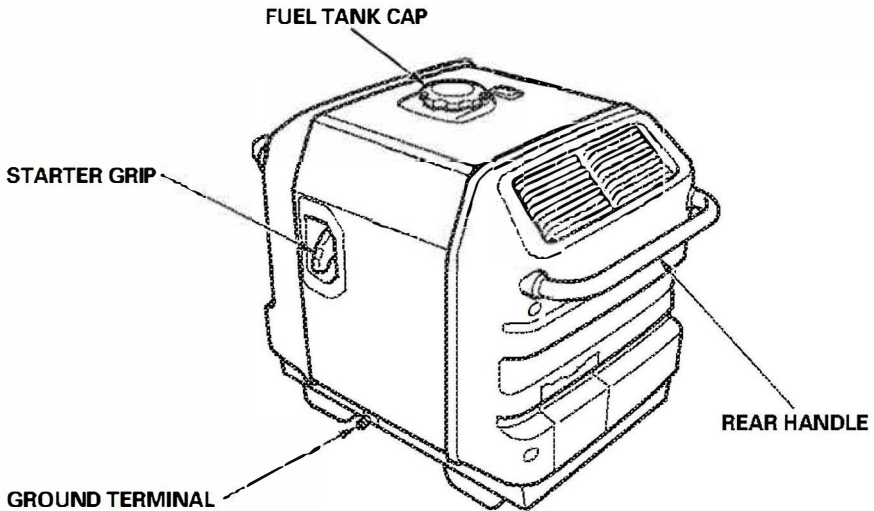
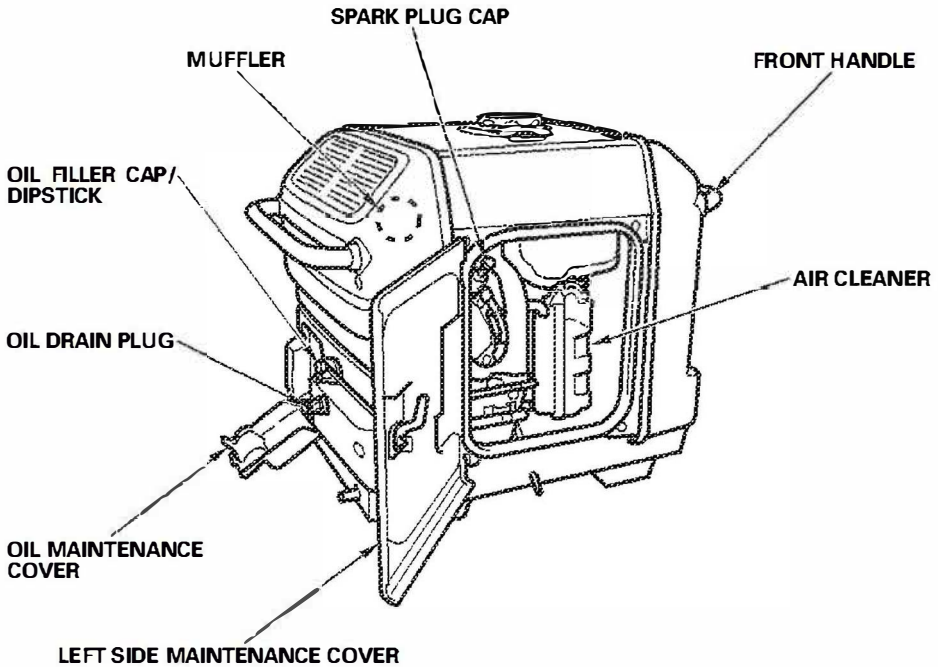

CONTROLS

Engine Switch

The engine switch controls the ignition system, and it operates the electric starter.

OFF — Stops the engine. The engine switch key can be removed/inserted.

ON — Running position, and for starting with the recoil starter.

START — Operates the electric starter.

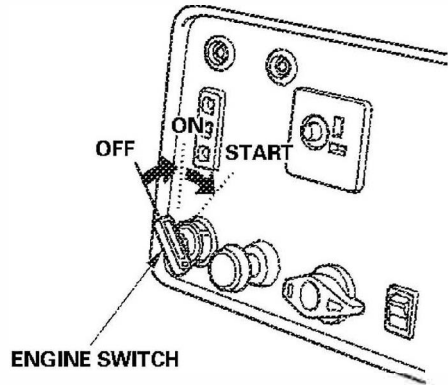

Starter Grip

Used when the battery voltage is too low to turn the starter motor. Pulling the starter grip operates the recoil starter to crank the engine.

NOTICE

Do not allow the starter grip to snap back against the generator. Return it gently to prevent damage to the starter.

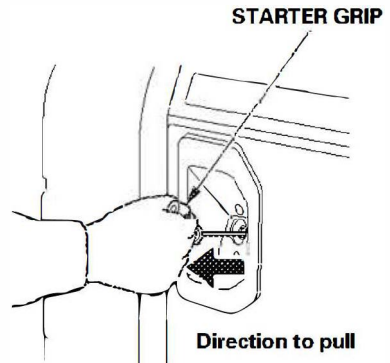

CONTROLS & FEATURES

Fuel Valve Lever

The fuel valve lever is located on the control panel.

The fuel valve must be in the ON position for the engine to run.

After stopping the engine, turn the fuel valve to the OFF position.

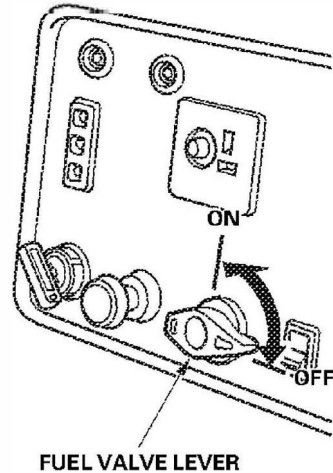

Choke Knob

The choke is used to provide proper starting mixture when the engine is cold. It can be opened and closed by operating the choke knob manually. Move the choke knob to the closed position to enrich the mixture for cold starting.

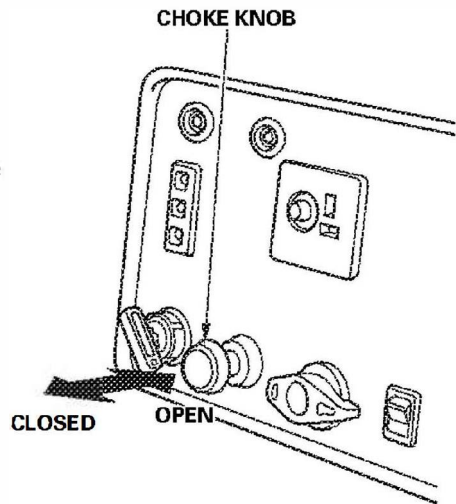

Eco-Throttle™ Switch

The Eco-Throttle™ system automatically reduces engine speed when loads are turned off or disconnected. When appliances are turned on or reconnected, the engine returns to the proper speed to power the electrical load.

If high electrical loads are connected simultaneously, turn the Eco-Throttle switch to the OFF position to reduce voltage changes.

- ON:** Recommended to minimize fuel consumption and further reduce noise levels when less than a full load is applied to the generator.
- OFF:** The Eco-Throttle system does not operate. Generator operates at full speed.

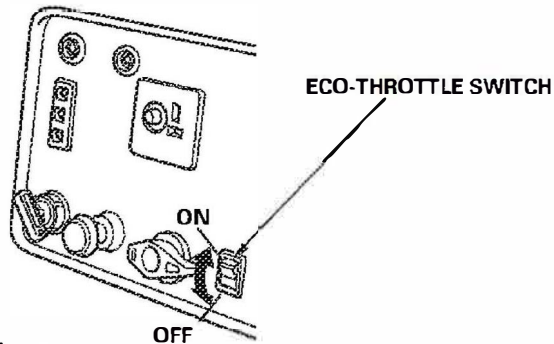

Parallel Operation Outlets

These outlets are used for connecting two EU3000is generators for parallel operation (see page 29). A Honda approved parallel operation cable kit (optional equipment) is required for parallel operation. This kit can be purchased from an authorized Honda generator dealer.

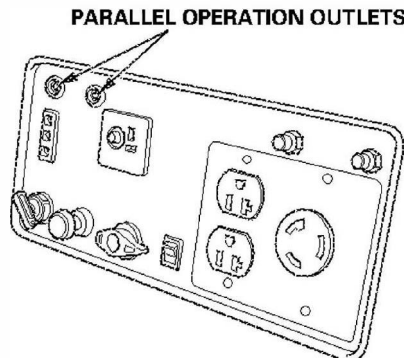

CONTROLS & FEATURES

AC Circuit Protector

The AC circuit protectors will automatically switch OFF if there is a short circuit or a significant overload of the generator at the 120V 20A receptacle or 120V 30A locking plug receptacle. If an AC circuit protector switches OFF automatically, check that the appliance is working properly and does not exceed the rated load capacity of the circuit before resetting the AC circuit protector ON.

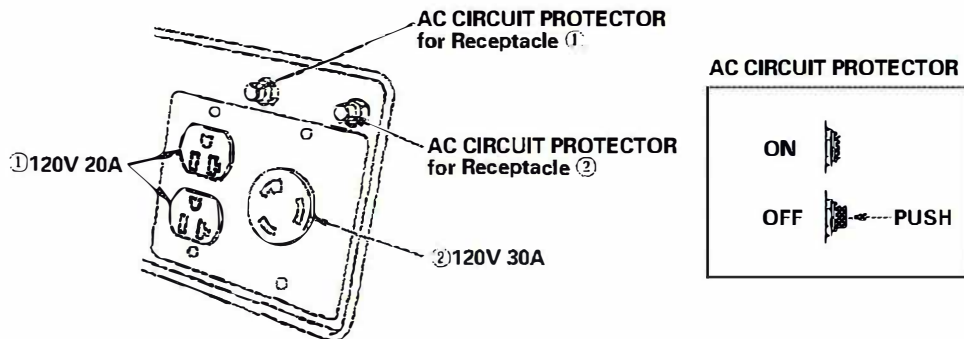

DC Receptacle

The DC receptacle should ONLY be used for charging 12-volt automotive type batteries. The DC charging output is not regulated.

DC Circuit Protector

The DC circuit protector automatically shuts off the DC battery charging circuit when the DC charging circuit is overloaded, when there is a problem with the battery, or when the connections between the battery and the generator are improper. However, the circuit protector does not prevent overcharging.

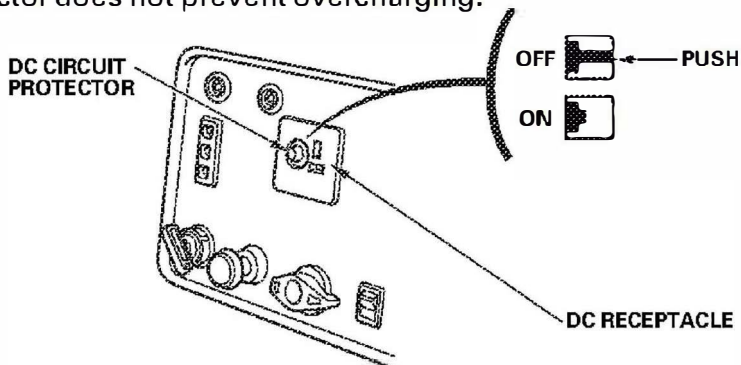

FEATURES

Output Indicator

The output indicator (green) is illuminated when the generator is operating normally. It indicates that the generator is producing electrical power at the receptacles.

OUTPUT INDICATOR
(GREEN)

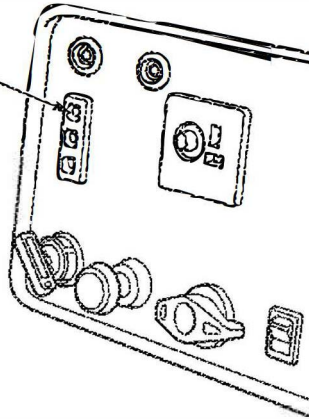

Overload Indicator

If the generator is overloaded (in excess of 3.0 kVA), or if there is a short circuit in a connected appliance, the overload indicator (red) will come ON. The overload indicator (red) will stay ON, and after about four seconds, current to the connected appliance(s) will shut off, and the output indicator (green) will go OFF. However, the engine will continue to run.

OVERLOAD INDICATOR
(RED)

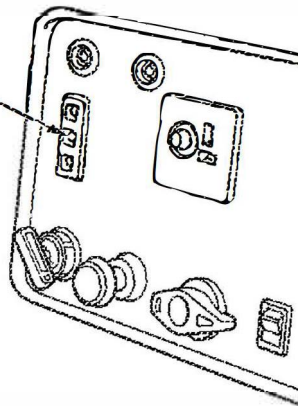

CONTROLS & FEATURES

Oil Alert® Indicator

The Oil Alert® system is designed to prevent engine damage caused by an insufficient amount of oil in the crankcase. Before the oil level in the crankcase can fall below a safe limit, the Oil Alert indicator (red) comes on and the Oil Alert system automatically will stop the engine (the engine switch will remain in the ON position).

If the engine stops or the Oil Alert indicator (red) comes on when you turn the engine switch to START position or pull the starter grip, check the engine oil level (see page 44) before troubleshooting in other areas.

OIL ALERT INDICATOR
(RED)

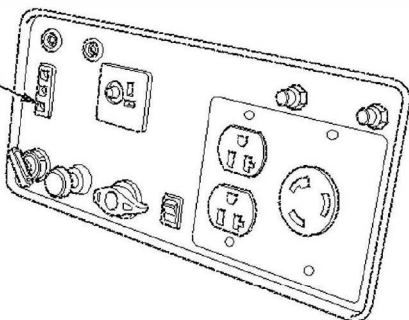

Ground Terminal

The generator ground terminal is connected to the frame of the generator, the metal non-current-carrying parts of the generator, and the ground terminals of each receptacle.

Before using the ground terminal, consult a qualified electrician, electrical inspector, or local agency having jurisdiction for local codes or ordinances that apply to the intended use of the generator.

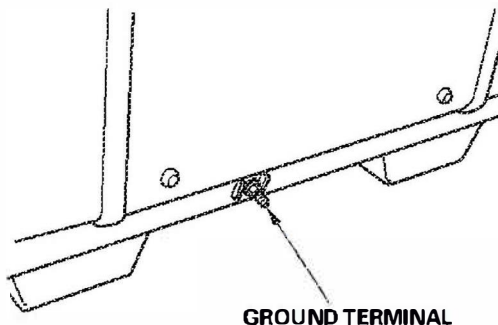

BEFORE OPERATION

ARE YOU READY TO GET STARTED?

Your safety is your responsibility. A little time spent in preparation will significantly reduce your risk of injury.

Knowledge

Read and understand this manual. Know what the controls do and how to operate them.

Familiarize yourself with the generator and its operation before you begin using it. Know how to quickly shut off the generator in case of an emergency.

If the generator is being used to power appliances, be sure that they do not exceed the generator's load rating (see pages 28 and 32).

IS YOUR GENERATOR READY TO GO?

For your safety, and to maximize the service life of your equipment, it is very important to take a few moments before you operate the generator to check its condition. Be sure to take care of any problem you find, or have your servicing dealer correct it, before you operate the generator.

▲ WARNING

Improperly maintaining this generator, or failing to correct a problem before operation, could cause a malfunction in which you could be seriously injured.

Always perform a pre-operation inspection before each operation, and correct any problem.

BEFORE OPERATION

To prevent a possible fire, keep the generator at least 3 feet (1 meter) away from building walls and other equipment during operation. Do not place flammable objects close to the engine.

Before beginning your pre-operation checks, be sure the generator is on a level surface and the engine switch is in the OFF position.

Check the Engine

Check the oil level (see page 44). A low oil level will cause the Oil Alert system to shut down the engine.

Check the air filter (see page 47). A dirty air filter will restrict air flow to the carburetor, reducing engine and generator performance.

Check the fuel level (see page 42). Starting with a full tank will help to eliminate or reduce operating interruptions for refueling.

OPERATION

SAFE OPERATING PRECAUTIONS

Before operating the generator for the first time, review chapters *GENERATOR SAFETY* (see page 6) and *BEFORE OPERATION* (see page 19).

For your safety, do not operate the generator in an enclosed area such as a garage. Your generator's exhaust contains poisonous carbon monoxide gas that can collect rapidly in an enclosed area and cause illness or death.

▲ WARNING

Exhaust contains poisonous carbon monoxide gas that can build up to dangerous levels in closed areas. Breathing carbon monoxide can cause unconsciousness or death.

Never run the generator in a closed, or even partly closed area where people may be present.

Before connecting an AC appliance or power cord to the generator:

- Use grounded 3-prong extension cords, tools, and appliances, or double-insulated tools and appliances.
- Inspect cords and plugs, and replace if damaged.
- Make sure that the appliance is in good working order. Faulty appliances or power cords can create a potential for electric shock.
- Make sure the electrical rating of the tool or appliance does not exceed that of the generator. Never exceed the maximum power rating of the generator. Power levels between rated and maximum may be used for no more than 30 minutes.
- Operate the generator at least 3 feet (1 meter) away from buildings and other equipment.
- Do not operate the generator in an enclosed structure.

OPERATION

STARTING THE ENGINE

To prevent a possible fire, keep the generator at least 3 feet (1 meter) away from building walls and other equipment during operation. Do not place flammable objects close to the engine.

NOTICE

Operating this generator less than 3 feet (1 meter) from a building or other obstruction can cause overheating and damage the generator. For proper cooling, allow at least 3 feet (1 meter) of empty space above and around the generator.

Refer to *SAFE OPERATING PRECAUTIONS* on page 21 and perform the *IS YOUR GENERATOR READY TO GO* checks (see page 19). Refer to *AC OPERATION* (see page 27) or *DC OPERATION* (see page 33) for connecting loads to the generator.

1. Make sure that all appliances connected to the generator are turned off. The generator may be hard to start if a load is connected.
2. Turn the fuel valve lever to the ON position.

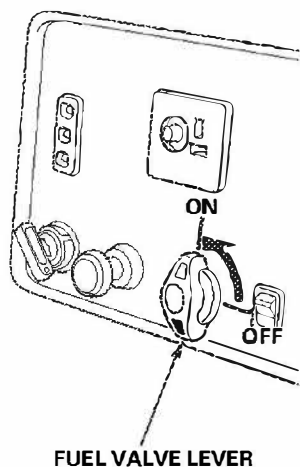

3. Make sure the Eco-Throttle switch is in the OFF position, or more time will be required for warm-up.

ECO-THROTTLE SWITCH

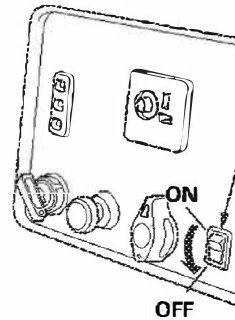

4. To start a cold engine, pull the choke knob out to the CLOSED position.
To restart a warm engine, leave the choke knob in the OPEN position.

CHOKE KNOB

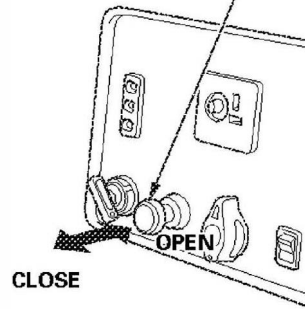

5. Turn the engine switch to the START position, and hold it there until the engine starts.
When the engine starts, release the key, allowing the switch to return to the ON position.

If the engine fails to start within 5 seconds, release the key, and wait at least 10 seconds before operating the starter again.

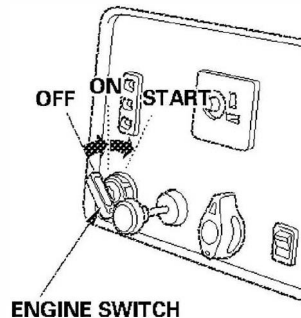

NOTICE

Using the electric starter for more than 5 seconds at a time will overheat the starter motor and can damage it.

Do not leave the engine switch in the ON position when the generator is not operating as the battery will discharge. Turn the engine switch to the OFF position when not in use.

OPERATION

6. If the choke knob was moved to the CLOSED position to start the engine, gradually push it to the OPEN position as the engine warms up.

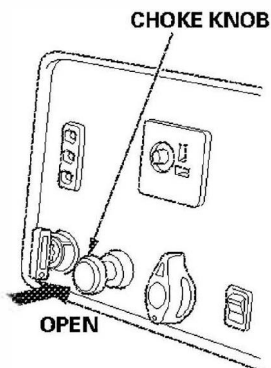

7. If you wish to use the Eco-Throttle system, turn the Eco-Throttle switch to the ON position after the engine has warmed up for 2 or 3 minutes.

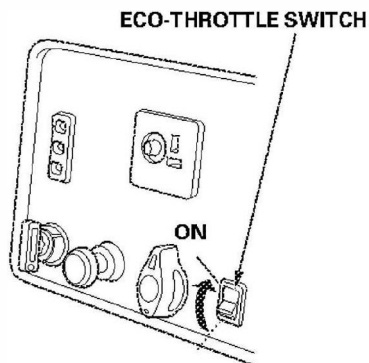

Manual starting:

1. Make sure that all appliances connected to the generator are turned off.
2. Turn the fuel valve lever to the ON position.
3. To start a cold engine, pull the choke knob out to the CLOSED position.
To restart a warm engine, leave the choke knob in the OPEN position.
4. Turn the engine switch to the ON position.

5. Pull the starter grip lightly until you feel resistance, then pull briskly in the direction of the arrow as shown.

NOTICE

Do not allow the starter grip to snap back against the generator. Return it gently to prevent damage to the starter.

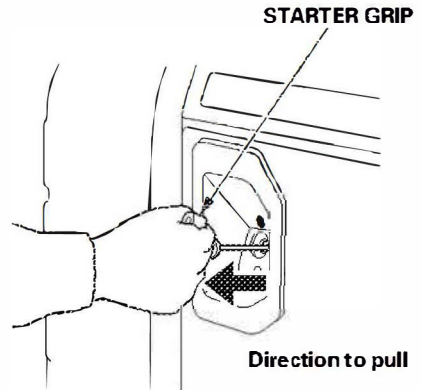

6. If the choke knob was moved to the CLOSED position to start the engine, gradually push it to the OPEN position as the engine warms up.
7. If you wish to use the Eco-Throttle system, turn the Eco-Throttle switch to the ON position after the engine has warmed up for 2 or 3 minutes.

OPERATION

STOPPING THE ENGINE

To stop the engine in an emergency, simply turn the engine switch to the OFF position. Under normal conditions, use the following procedure.

1. Turn off or disconnect all appliances that are connected to the generator or the parallel operation kit.
2. Turn the engine switch to the OFF position.

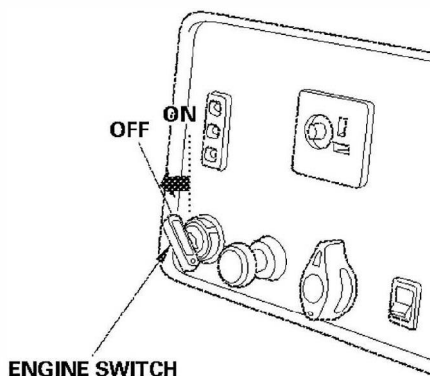

3. Turn the fuel valve lever to the OFF position.

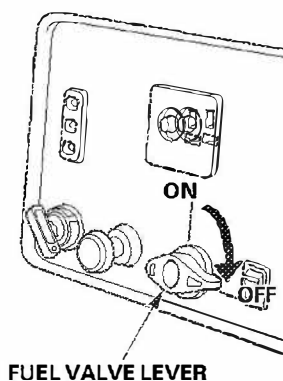

4. If two generators were connected for parallel operation, disconnect the parallel operation kit/receptacle assembly after stopping the engines if you do not wish to resume parallel operation.

AC OPERATION

Before connecting an appliance to the generator, make sure that it is in good working order and that its electrical rating does not exceed that of the generator.

Most motorized appliances require more than their electrical rating for startup. When an electric motor is started, the overload indicator (red) may come on. This is normal if the overload indicator (red) goes off within 4 seconds. If the overload indicator (red) stays on, consult your generator dealer.

1. Start the engine (see page 22) and make sure the output indicator (green) comes on.
2. Plug in the appliance.

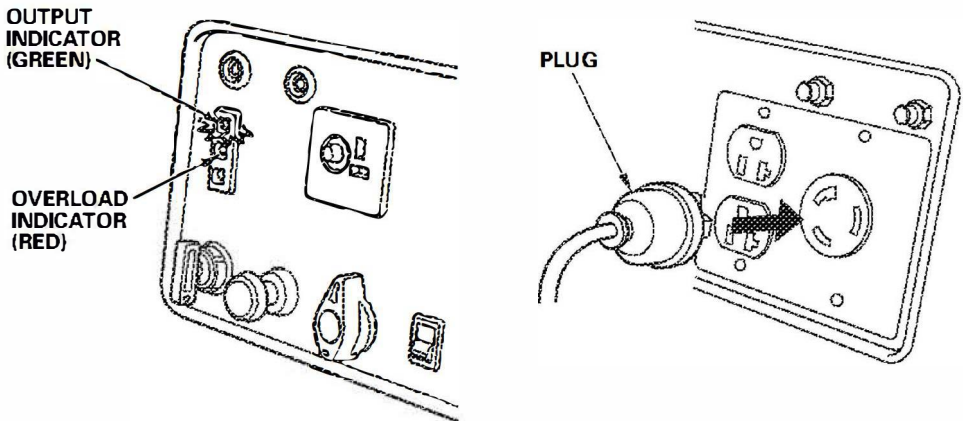

3. Turn on the appliance.

If the generator is overloaded (in excess of 3.0 kVA), if there is a short circuit in a connected appliance, or if the inverter is overheated, the overload indicator (red) will come ON. The overload indicator (red) will stay ON, and after about five seconds, current to the connected appliance(s) will shut off, and the output indicator (green) will go OFF. Stop the engine and investigate the problem.

Determine if the cause is a short circuit in a connected appliance, an overload, or an overheated inverter. Correct the problem and restart the generator.

OPERATION

AC Applications

Before connecting an appliance or power cord to the generator:

- Make sure that it is in good working order. A faulty appliance or power cord can create a potential for electrical shock.
- If an appliance begins to operate abnormally, becomes sluggish, or stops suddenly, turn it off immediately. Disconnect the appliance, and determine whether the problem is the appliance or the rated load capacity of the generator has been exceeded.
- Make sure that the combined electrical rating of the tools or appliances do not exceed that of the generator. Never exceed the maximum power rating of the generator. Power levels between rated and maximum may be used for no more than 30 minutes.

NOTICE

Substantial overloading that continuously lights the red overload indicator may damage the generator. Marginal overloading that temporarily lights the red overload indicator may shorten the service life of the generator.

Limit operation requiring maximum power to 30 minutes.
Maximum power is:

3.0 kVA

For continuous operation, do not exceed the rated power.
Rated power is:

2.8 kVA

The total power requirements (VA) of all appliances connected must be considered. Appliance and power tool manufacturers usually list rating information near the model number or serial number.

AC PARALLEL OPERATION

Before connecting an appliance to either generator, make sure that the appliance is in good working order and that its electrical rating does not exceed that of the receptacle.

Most motorized appliances require more than their electrical rating for startup. When an electric motor is started, the overload indicator (red) may come on. This is normal if the overload indicator (red) goes off within 4 seconds. If the overload indicator (red) stays on, consult your generator dealer.

1. Connect the parallel operation kit between the two EU3000is generators following the instructions supplied with the kit.

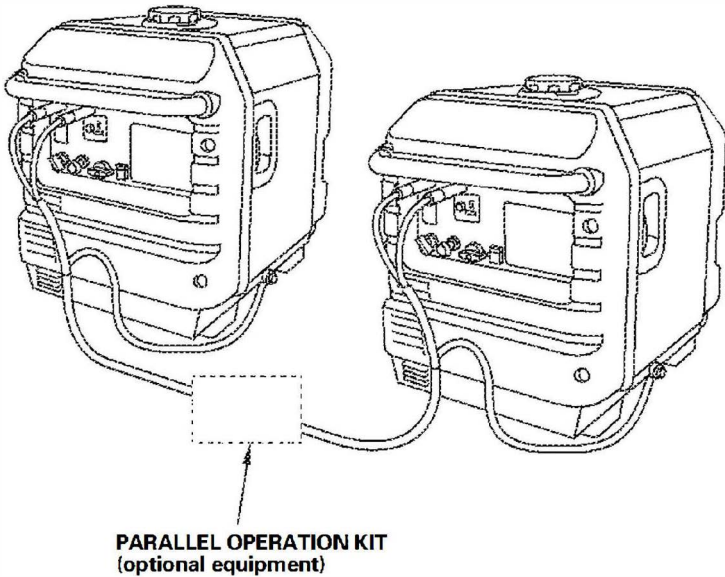

2. Start the generators (see page 22) and make sure the output indicator (green) on each generator comes on.

OPERATION

3. Plug in the appliance following the instruction provided with the parallel operation cable kit.
4. Turn on the appliance.

If the generators are overloaded (see page 32), or if there is a short circuit in a connected appliance, the overload indicator (red) will go ON. The overload indicator (red) will stay ON, and after about four seconds, current to the connected appliance(s) will shut off, and the output indicator (green) will go OFF. Stop the engines and investigate the problem.

Determine if the cause is a short circuit in a connected appliance, an overload, or an overheated inverter. Correct the problem and restart the generator.

AC Parallel Operation Applications

Follow the instructions included with the parallel operation cable kit.

Before connecting an appliance or power cord to the generator:

- Make sure that it is in good working order. A faulty appliance or power cord can create a potential for electrical shock.
- If an appliance begins to operate abnormally, becomes sluggish, or stops suddenly, turn it off immediately. Disconnect the appliance, and determine whether the problem is the appliance or the rated load capacity of the generator has been exceeded.
- Make sure that the combined electrical rating of the tools or appliances do not exceed that of the generator. Never exceed the maximum power rating of the generator. Power levels between rated and maximum may be used for no more than 30 minutes.
- Never connect different generator models and types.
- Use only a Honda approved parallel operation kit (optional equipment) when connecting two EU3000iS generators for parallel operation.
- Never connect or remove the parallel operation kit when the generator is running.
- For single generator operation, the parallel operation kit must be removed.

NOTICE

Substantial overloading that continuously lights the overload indicator (red) may damage the generator. Marginal overloading that temporarily lights the overload indicator (red) may shorten the service life of the generator.

OPERATION

Limit operation requiring maximum power to 30 minutes.
Maximum power in parallel operation is:

6.0 kVA

For continuous operation, do not exceed the rated power.
Rated power in parallel operation is:

5.6 kVA

The total power requirements (VA) of all appliances connected must be considered. Appliance and power tool manufacturers usually list rating information near the model number or serial number.

DC OPERATION

The DC receptacle should ONLY be used for charging 12-volt automotive type batteries. The DC charging output is not regulated.

DC output will vary according to the position of the Eco-Throttle switch. When the Eco-Throttle switch is turned to the ON position and the AC output is not used, the DC current will be about one-third of the rated current.

DC Current

Eco-Throttle switch	OFF	ON (Do not use the AC output)
Model		
EU3000is	12 A	approximately 4 A

Connecting the battery charging cable (optional equipment):

1. Before connecting the battery charging cable (optional equipment) to a battery that is installed in a vehicle, disconnect the vehicle battery ground cable from the negative (-) battery terminal.

▲ WARNING

The battery gives off explosive hydrogen gas during normal operation.

A spark or flame can cause the battery to explode with enough force to kill or seriously hurt you.

Wear protective clothing and a face shield, or have a skilled mechanic perform the battery maintenance.

WARNING: Battery posts, terminals, and related accessories contain lead and lead components. **Wash hands after handling.**

OPERATION

2. Plug the battery charging cable into the DC receptacle of the generator.
3. Connect the red lead of the battery charging cable to the positive (+) battery terminal and the black lead to the negative (-) battery terminal.

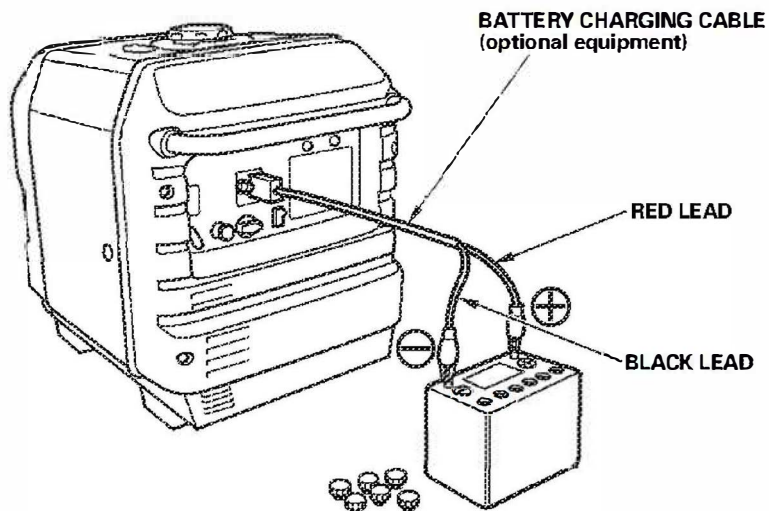

4. Start the generator.

NOTICE

Do not start the vehicle while the battery charging cable is connected and the generator is running. The vehicle or the generator may be damaged.

An overloaded DC circuit, excessive current drawn by the battery, or a wiring problem will trip the DC circuit protector (the yellow indicator inside the clear circuit protector button will pop out). If this happens, wait a few minutes before pushing in the circuit protector button to resume operation. If the circuit protector continues to go OFF, discontinue charging and see your authorized Honda generator dealer. The DC circuit protector does not prevent overcharging the battery.

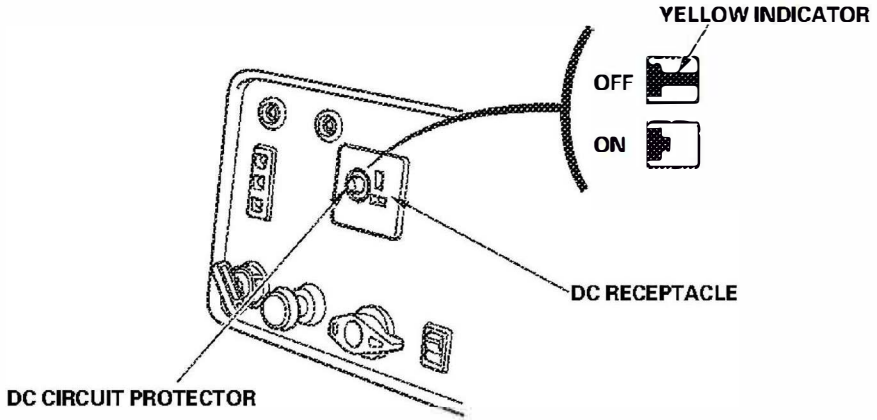

Disconnecting the battery charging cable:

1. Stop the engine.
2. Disconnect the black lead of the battery charging cable from the negative (-) battery terminal.
3. Disconnect the red lead of the battery charging cable from the positive (+) battery terminal.
4. Disconnect the battery charging cable from the DC receptacle of the generator.
5. Connect the vehicle battery ground cable to the negative (-) battery terminal.

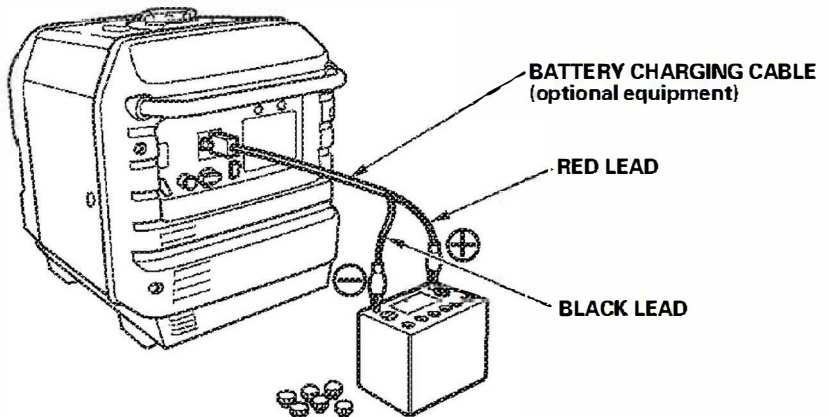

OPERATION

ECO-THROTTLE™ SYSTEM

With the switch in the ON position, engine speed is automatically lowered when loads are reduced, turned off, or disconnected. When appliances are turned on or reconnected, the engine returns to the proper speed to power the electrical load. In the OFF position, the Eco-Throttle system does not operate.

Appliances with large start-up power demands may not allow the engine to reach normal operating rpm when they are connected to the generator. Turn the Eco-Throttle switch to the OFF position and connect the appliance to the generator. If the engine still will not reach normal operating speed, check that the appliance does not exceed the rated load capacity of the generator.

If high electrical loads are connected simultaneously, turn the Eco-Throttle switch to the OFF position to reduce voltage changes.

The Eco-Throttle system is not effective for use with appliances or tools that require only momentary power. If the tool or appliance will be turned ON and OFF quickly, the Eco-Throttle switch should be in the OFF position.

When using the DC output, turn the Eco-Throttle switch to the OFF position.

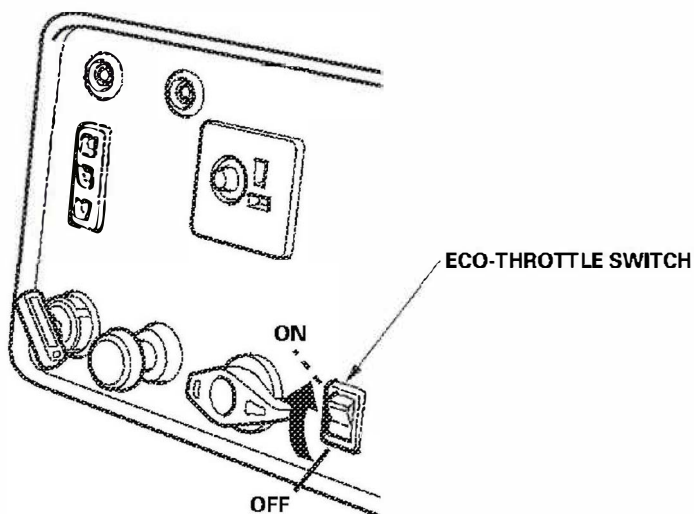

STORAGE

STORAGE PREPARATION

Proper storage preparation is essential for keeping your generator trouble-free and looking good. The following steps will help to keep rust and corrosion from impairing your generator's function and appearance, and will make the engine easier to start when you use the generator again.

Cleaning

Wipe the generator with a **moist** cloth. After the generator has dried, touch up any damaged paint, and coat other areas that may rust with a light film of oil.

Fuel

NOTICE

Depending on the region where you operate your equipment, fuel formulations may deteriorate and oxidize rapidly. Fuel deterioration and oxidation can occur in as little as 30 days and may cause damage to the carburetor and/or fuel system. Please check with your servicing dealer for local storage recommendations.

Gasoline will oxidize and deteriorate in storage. Old gasoline will cause hard starting, and it leaves gum deposits that clog the fuel system. If the gasoline in your generator deteriorates during storage, you may need to have the carburetor and other fuel system components serviced or replaced.

The length of time that gasoline can be left in your fuel tank and carburetor without causing functional problems will vary with such factors as gasoline blend, your storage temperatures, and whether the fuel tank is partially or completely filled. The air in a partially filled fuel tank promotes fuel deterioration. Very warm storage temperatures accelerate fuel deterioration. Fuel deterioration problems may occur within a few months, or even less if the gasoline was not fresh when you filled the fuel tank.

The *Distributor's Limited Warranty* does not cover fuel system damage or engine performance problems resulting from neglected storage preparation.

You can extend fuel storage life by adding a gasoline stabilizer that is formulated for that purpose, or you can avoid fuel deterioration problems by draining the carburetor, sediment cup (if applicable) and/or fuel tank.

TRANSPORTING

NOTICE

Do not lay the generator on its side when moving, storing, or operating it. Oil or fuel may leak and damage the engine or your property.

If the generator has been used, allow it cool for at least 15 minutes before loading the generator on the transport vehicle. A hot engine and exhaust system can burn you and can ignite some material. When transporting the generator, turn the engine switch and the fuel valve OFF, and keep the generator level to reduce the possibility of fuel leakage.

Take care not to drop or strike the generator when transporting. Do not place heavy objects on the generator.

TAKING CARE OF UNEXPECTED PROBLEMS

ENGINE WILL NOT START

Possible Cause	Correction
Fuel valve lever OFF.	Turn lever ON (p. 22).
Engine switch OFF.	Turn engine switch to ON (p. 23).
Out of fuel.	Refuel (p. 42).
Bad fuel; generator stored without treating or draining gasoline, or refueled with bad gasoline.	Drain fuel tank and carburetor (p. 63). Refuel with fresh gasoline (p. 42).
Low oil level caused Oil Alert to stop engine.	Add oil (p. 44). Turn engine switch to OFF and then restart the engine.
Spark plug faulty, fouled, or improperly gapped.	Gap or replace spark plug (p. 49).
Spark plug wet with fuel (flooded engine).	Dry and reinstall spark plug.
Fuel filter restricted, carburetor malfunction, ignition malfunction, valves stuck, etc.	Take the generator to an authorized Honda servicing dealer, or refer to the shop manual.

TAKING CARE OF UNEXPECTED PROBLEMS

ENGINE LACKS POWER

Possible cause	Correction
Air filter restricted.	Clean or replace air filter (p. 47, 48).
Bad fuel; generator stored without treating or draining gasoline, or refueled with bad gasoline.	Drain fuel tank and carburetor (p. 63). Refuel with fresh gasoline (p. 42).
Fuel filter restricted, carburetor malfunction, ignition malfunction, valves stuck, etc.	Take the generator to an authorized Honda servicing dealer, or refer to the shop manual.

TAKING CARE OF UNEXPECTED PROBLEMS

NO POWER AT THE AC RECEPTACLES

Possible Cause	Correction
Output indicator is OFF, and overload indicator is ON.	Check AC load. Stop and restart the engine.
	Check the cooling air inlet. Stop and restart the engine.
AC Circuit protector tripped.	Check AC load and reset circuit protector (p. 16).
Faulty power tool or appliance.	Replace or repair power tool or appliance. Stop and restart the engine.
Faulty generator.	Take the generator to an authorized Honda servicing dealer, or refer to the shop manual.

NO POWER AT THE DC RECEPTACLE

Possible Cause	Correction
DC circuit protector OFF.	Turn DC circuit protector ON (p. 16).
Faulty generator.	Take the generator to an authorized Honda servicing dealer, or refer to the shop manual.